

RGB2SSHCH

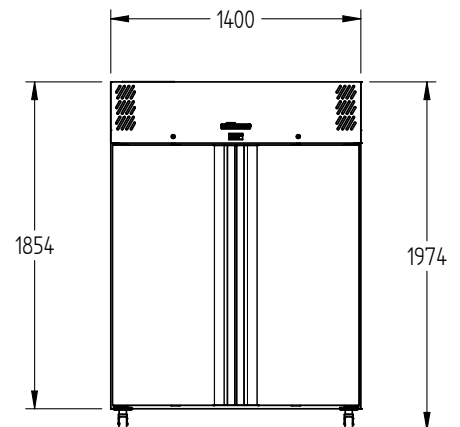

CATEGORY	BAKERY
RANGE	Garnet Bakery
UNIT	RETARDER
TYPE	SELF CONTAINED
DOORS	2

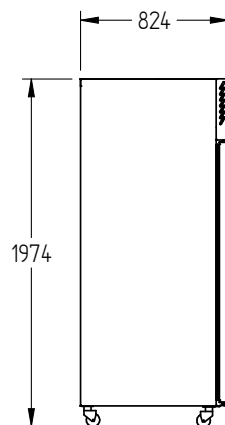
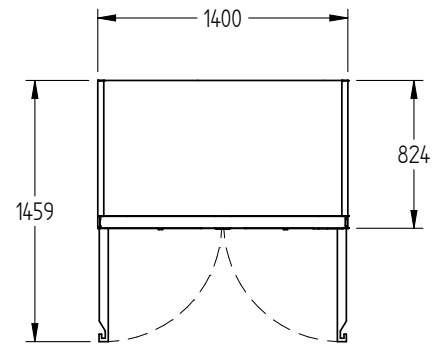

SPECIFICATIONS

CAPACITY LITRES	1270
TEMPERATURE - 43°C AMBIENT ENVIRONMENT	-5°C / +3°C
DIMENSIONS - W X D X H (ON CASTORS) MM	1400 W x 824 D x 1974 H
WEIGHT UNPACKED (KG)	220

STANDARD INCLUSIONS ***

DOOR TYPE	Standard: S (Solid Door)
FINISH (INTERIOR AND EXTERIOR EXCLUDING REAR AND UNDER)	S (Stainless Steel)
TRAY SLIDES PER DOOR (NO TRAYS OR SHELVES SUPPLIED)(ACCOMODATES 600 MM X 400MM TRAYS)	10

ELECTRICAL

POWER SUPPLY	10 amp
POWER CABLE LENGTH (METRES)	2
RUNNING AMPS	1.4

GAS TYPE

REFRIGERANT	R290
-------------	------

REFRIGERATION WATTAGES FOR OPTIONAL REMOTE UNITS

FRIDGE MODELS - SOLID DOORS	670 @ -5°C SST
-----------------------------	----------------

*** For **OPTIONS** refer to the current Williams Price Guide