

LT2SS



CATEGORY | TOPAZ CAFÉ RANGE

RANGE | **Topaz Upright**

UNIT | FREEZER

TYPE | SELF CONTAINED

DOORS | 2

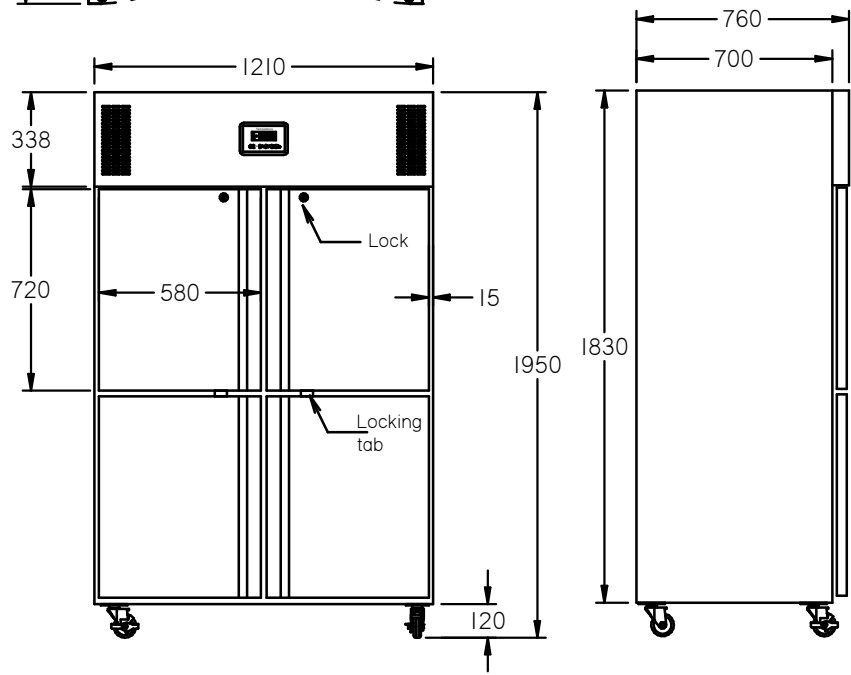
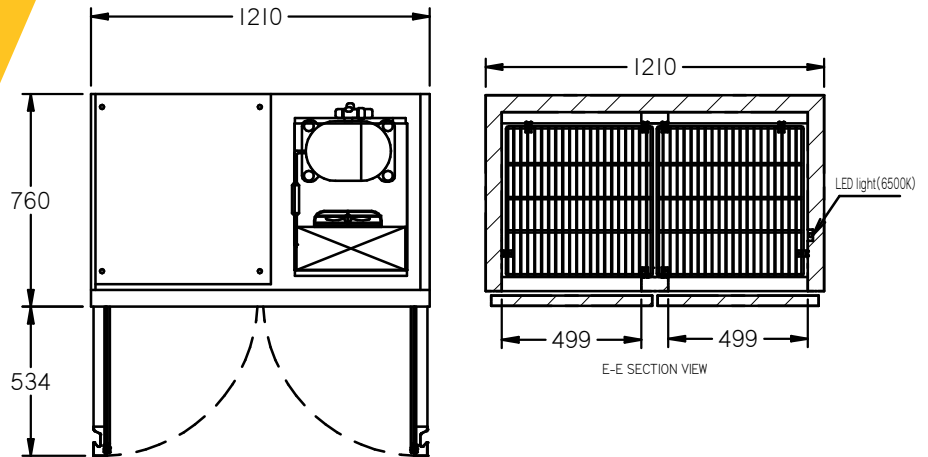

ELEVATION

SIDE VIEW

SPECIFICATIONS

CAPACITY LITRES	895
TEMPERATURE	-18°C / -22°C
DIMENSIONS - W X D X H (ON 120 MM H CASTORS) MM	1210W x 760 D x 1950 H
WEIGHT UNPACKED (KG)	146
STANDARD INCLUSIONS	
DOOR TYPE/SPLIT	Standard: S (Solid Door)
FINISH (INTERIOR AND EXTERIOR EXCLUDING REAR AND UNDER)	S (Stainless Steel) interior and exterior excluding rear and under
SHELVES/DOOR (ADJUSTABLE STRIPS AND CLIPS)	8
GAS TYPE	
REFRIGERANT	R404a

ELECTRICAL

POWER SUPPLY	10 amp
POWER CABLE LENGTH (METRES)	2
RUNNING AMPS	3.1
PERFORMANCE	
KWH/24H READING	13.65
TEST CONDITIONS	L1
AMBIENT RATING	38°C