

LAZ5UCSADR2-HC

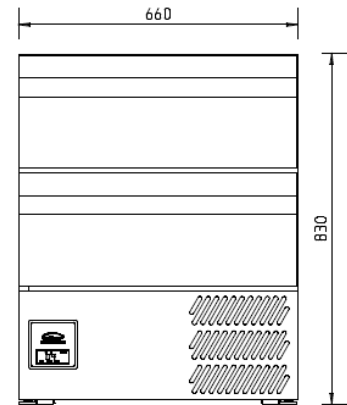

CATEGORY	HYDROCARBON
RANGE	Aztra
UNIT	FREEZER
TYPE	SELF CONTAINED
DRAWERS	2

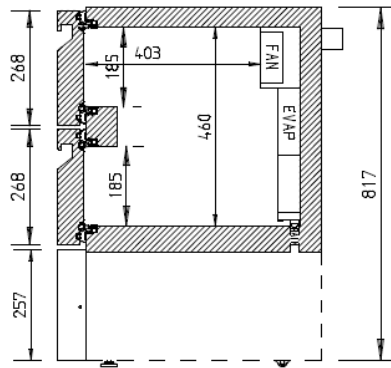
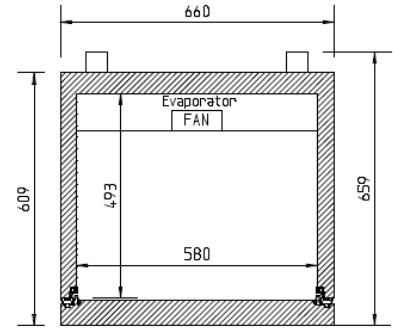

SPECIFICATIONS

CAPACITY LITRES	131
TEMPERATURE	-18°C / -22°C
DIMENSIONS - W X D X H (ON CASTORS) MM	660 W x 609 D x 830 H
WEIGHT UNPACKED (KG)	150

STANDARD INCLUSIONS

DRAWER TYPE	Full Drawer
FINISH (INTERIOR AND EXTERIOR EXCLUDING REAR AND UNDER)	SA (Stainless Steel Exterior, Aluminium Interior)
DRAWERS	2

GAS TYPE

REFRIGERANT	R290
-------------	------

ELECTRICAL

POWER SUPPLY	10 amp
POWER CABLE LENGTH (METRES)	2
RUNNING AMPS	2.46

PERFORMANCE

KWH/24HR READING	4.1
TEST STANDARD	EN 16825 (Professional)
TEST CONDITIONS	4 L1
AMBIENT RATING	43°C